



# MODEL GP-2000CS PRESSURE REDUCING VALVE PRODUCT MANUAL

Thank you very much for choosing the Yoshitake's product. To ensure the correct and safe use of the product, please read this manual before use. This manual shall be kept with care for future references. The symbols used in this manual have the following meanings.

	<b>Warning</b>	This symbol indicates a potentially hazardous situation that, if not avoided, could result in death or serious injury.
	<b>Caution</b>	This symbol indicates a hazardous situation that, if not avoided, may result in minor or moderate injury or may result in only property damage.

## Table of Contents

1. Usage of the Product	1
2. Specifications	1
3. Operation	2
4. Nominal Size Selection method	5
4.1 Pressure reducing valve specification selection chart	5
4.2 Characteristic chart	6
4.3 Nominal size selection chart	7
4.4 Nominal size selection calculation formula	8
4.5 Set pressure of safety valve for alarm use at the outlet side of the pressure reducing valve	8
5. Installation	9
5.1 Piping example	9
5.2 Precaution for installation	9
5.3 Warning for installing a sensing pipe	10
5.4 Piping example of a sensing pipe	10
6. Operation procedure	11
6.1 Precaution for operation	11
6.2 Adjusting procedure	11
7. Troubleshooting	12
7.1 Troubleshooting	12
7.2 Precaution for maintenance and inspection	13
7.3 Daily and periodic inspections	13
7.4 Disassembly	14
7.5 Precaution for reassembly	14
7.6 Exploded view	15

Warranty Information

## 1. Usage of the Product

The GP-2000CS pressure reducing valve for steam is pilot operated diaphragm type, which can control larger flow of fluid than piston type, offering superior controllability for pressure fluctuation of inlet side or load fluctuation of outlet side. It can be widely used in building utilities systems, air-conditioning systems and factory systems.

## 2. Specifications

Model	GP-2000CS								
Connection	Screwed			SW	Flanged				
	JIS Rc	NPT	JIS SW	JIS 30K RF	ASME class 300	EN 25/40	JIS 20K RF	JIS 10K FF	ASME class 150
Nominal size	15 – 50A			15 – 100A					
Application	Steam								
Installation posture	Horizontal piping								
Reduced pressure sensing method	External sensing*								
Inlet pressure	0.1-3.0 MPa				0.1-2.0 MPa		0.1-1.0 MPa		
Reduced pressure	0.02-0.15 MPa				0.02-0.15 MPa		0.02-0.15 MPa		
	0.1-1.4 MPa				0.1-1.4 MPa		0.1-0.85 MPa		
	1.3-2.0 MPa				1.3-1.7 MPa				
	85% or less of Inlet pressure (gauge pressure)								
Min. differential pressure	0.05 MPa								
Max. pressure reducing ratio	20:1								
Max. temperature	260°C								
Valve seat leakage	0.01% or less of rated flow								
Material	Spring case	WCB							
	Valve	Stellite overlaid SUS304							
	Valve seat	Stellite overlaid SUS304							
	Pilot valve, pilot valve seat	SUS420J2							
	Diaphragm	SUS301CSP							

\*Please have a sensing pipe at your end. Joint size is below:

JIS Rc, JIS SW, JIS 10K FF, 20K RF and 30K RF:

Rc 1/4

NPT, ASME class 150 and 300:

NPT 1/4



### Caution

Please confirm that the indications on the product correspond with the specifications of the ordered product model before use.

\* If they are different, please contact us without using the product.

### 3. Operation

The pressure reducing valve reduces pressure by throttling action, which is composed of main valve, main valve seat (for throttling), adjusting spring, pilot diaphragm, pilot valve and main diaphragm (for adjusting function).

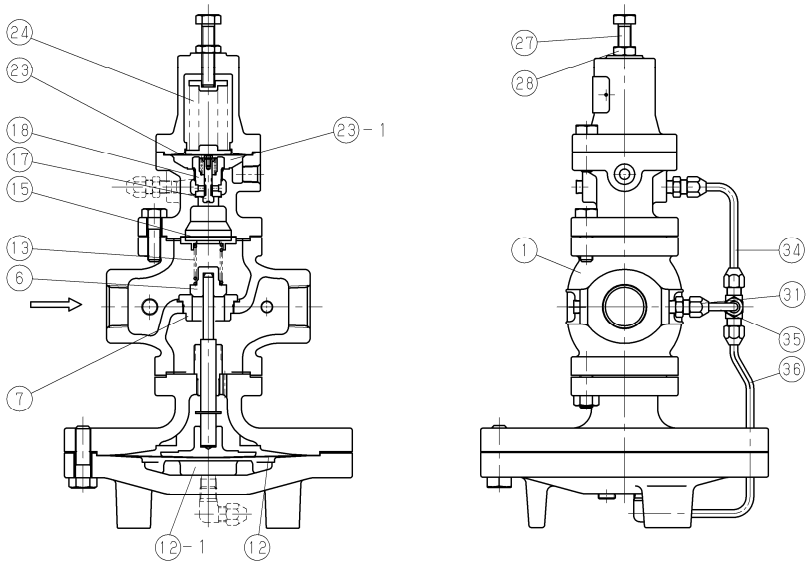

No.	Parts name
1	Body
6	Main valve
7	Main valve seat
12	Main diaphragm
13	Main valve spring
15	Screen
17	Pilot valve
18	Pilot valve seat
23	Pilot diaphragm
24	Adjusting spring
27	Adjusting screw
28	Lock nut
31	Joint
34,35,36	Pipe A,B,C
12-1	Main diaphragm chamber
23-1	Pilot diaphragm chamber

(1) When the adjusting spring [24] is free of load, the main valve [6] and pilot valve [17] are closed. When opening the gate valve slowly and allowing high pressure fluid to flow in, inlet pressure is applied to upside of the main valve and high pressure fluid passes through the screen [15] to also apply the inlet pressure to downside of the pilot valve (see Fig. 1 below).

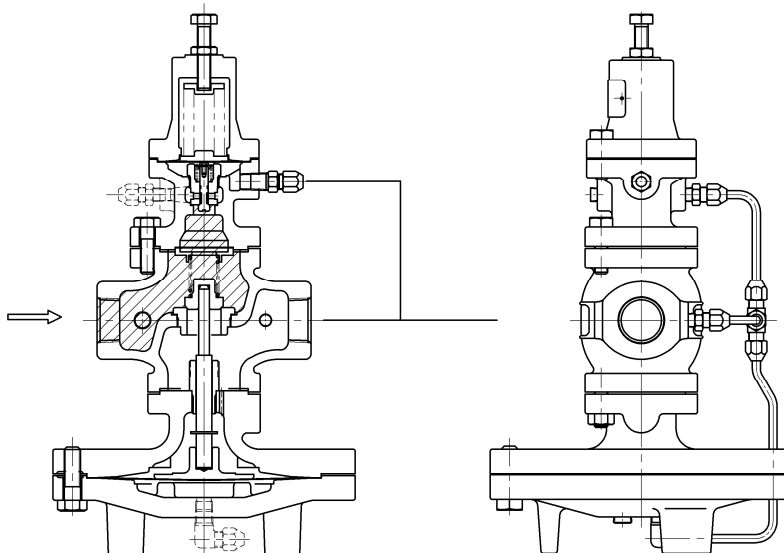

**Fig. 1**

- (2) Turning the adjusting screw [27] clockwise compresses the spring, which bends the pilot diaphragm [23] to open the pilot valve [17]. The fluid which passes through the pilot valve [17] and pilot valve seat [18] enters the main diaphragm chamber [12-1] via the pipe A [34] and pipe C [36]. The fluid also flows to outlet side of the body [1] through the pipe B [35] and the orifice of the joint B [31] connected to the body (see Fig. 2 below).

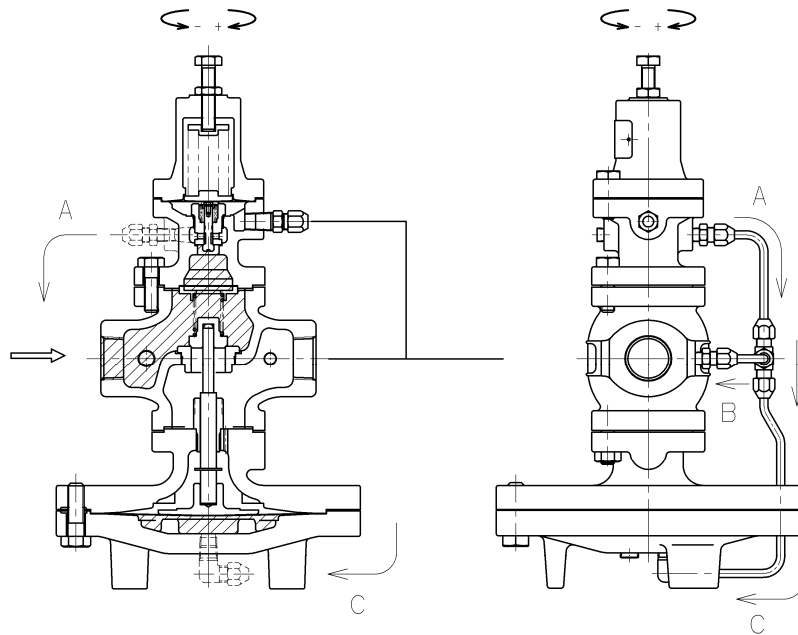

**Fig. 2**

- (3) When the flow rate through the pilot valve increase, the operating pressure in the main diaphragm chamber rises to override the pressure on upside of the main valve and the load of the main valve spring [13], opening the main valve. The fluid then begins to flow from the inlet side to the outlet side (see Fig. 3 below).

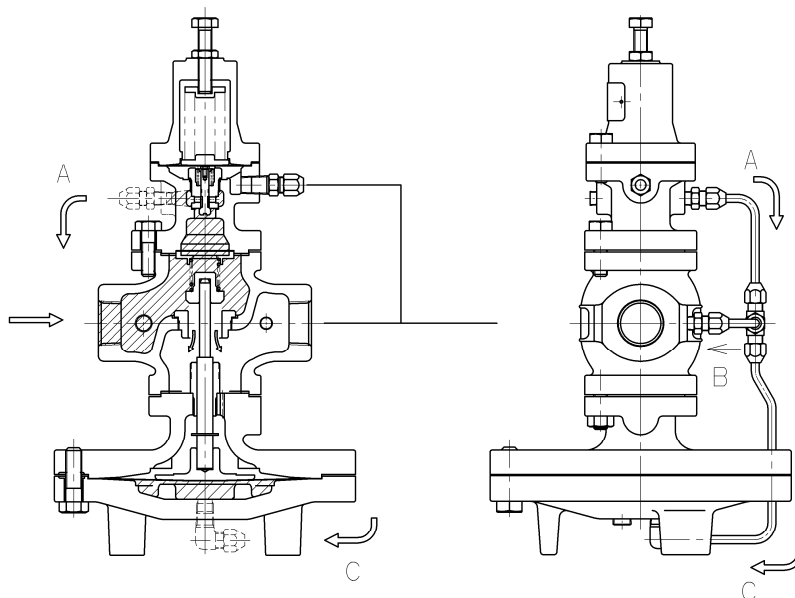

**Fig. 3**

- (4) The pressure flowing to the outlet side is led to the pilot diaphragm chamber [23-1] via the sensing pipe. The pilot diaphragm receives the reduced pressure to be balanced with the load of the adjusting spring [24]. The pilot valve travel is controlled by the spring load and pressure applied to the pilot diaphragm due to variations in reduced pressure. It changes the flow rate of fluid through the main diaphragm chamber, which controls the main valve travel to obtain appropriate reduced pressure (see Fig. 4 below).

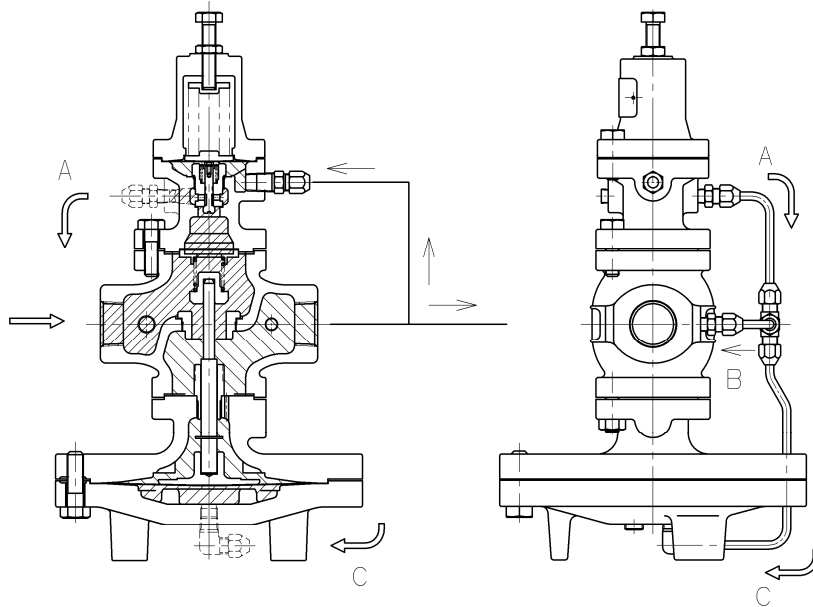

**Fig. 4**

- (5) When fluid does not flow at the outlet side, the pressure in the pilot diaphragm chamber rises to close the pilot valve. Then the operating pressure in the main diaphragm chamber becomes equal to reduced pressure and the main valve is closed by pressing force of the main valve spring (see Fig. 5 below).

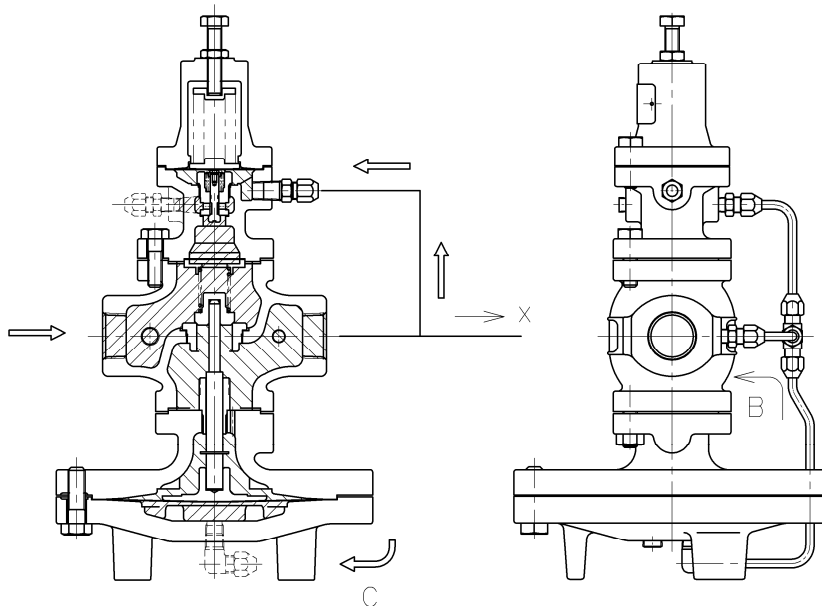

**Fig. 5**

## 4. Nominal size selection method

### 4.1 Pressure reducing valve specification selection chart

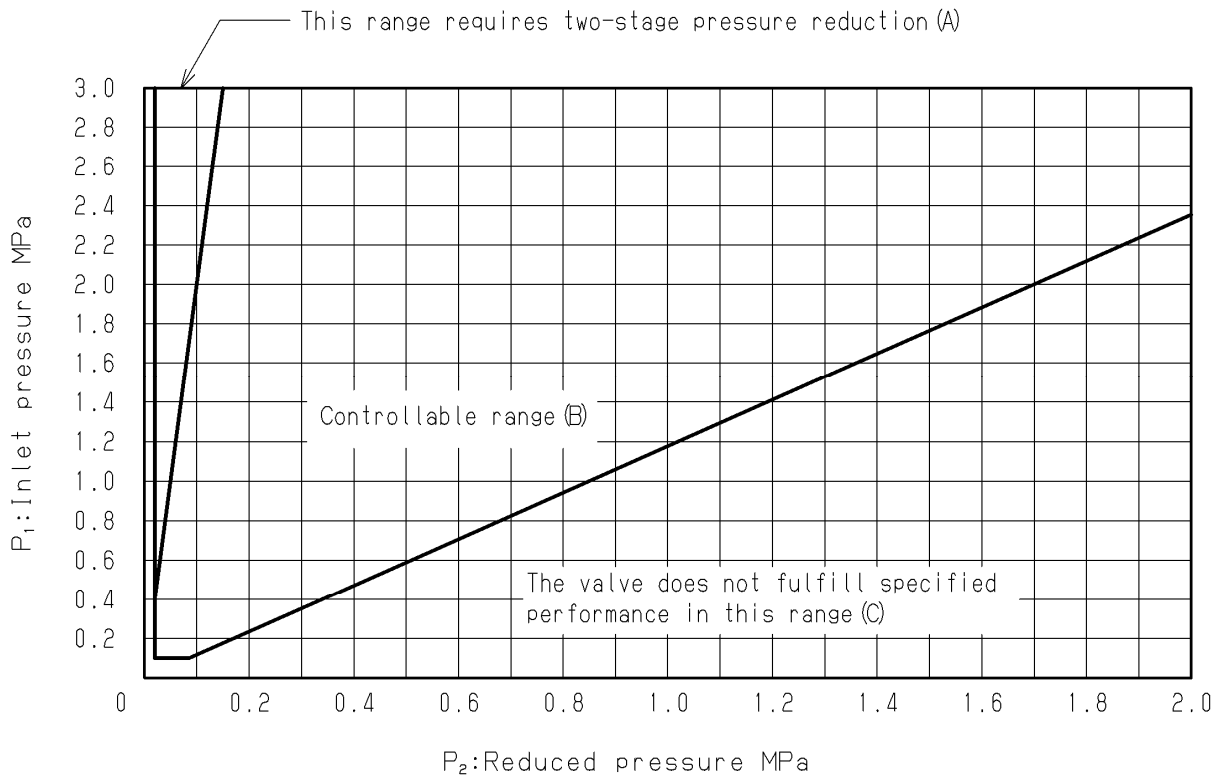

To select the most appropriate pressure reducing valve, refer to the above selection chart. Find the intersection point of the inlet pressure ( $P_1$ ) and the reduced pressure ( $P_2$ ). If the intersection point is within the range (A), two-stage pressure reduction is required. In this case, maximize the distance between the valves (at least 3 meters). The valve does not fulfill specified performance in the range (C).

## 4.2 Characteristic chart

### (1) Flow rate characteristics chart

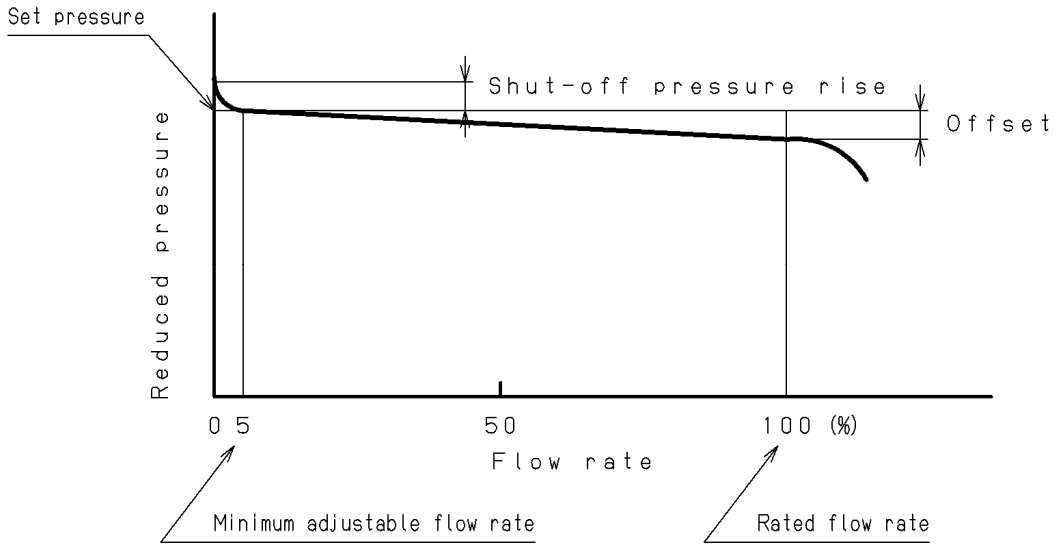

Shut-off pressure rise: 0.02 MPa or less

Offset: 10% or less of setting pressure at outlet side (Minimum value: 0.02MPa)

### (2) Pressure characteristics chart

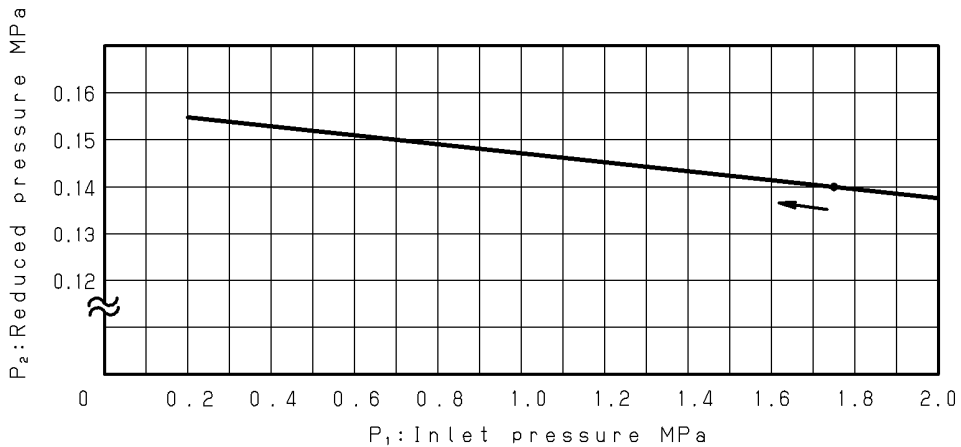

This chart shows variation in reduced pressure when the inlet pressure of 1.75 MPa is changed between 0.2 MPa and 2.0 MPa while the reduced pressure is set at 0.14 MPa.

### 4.3 Nominal size selection chart

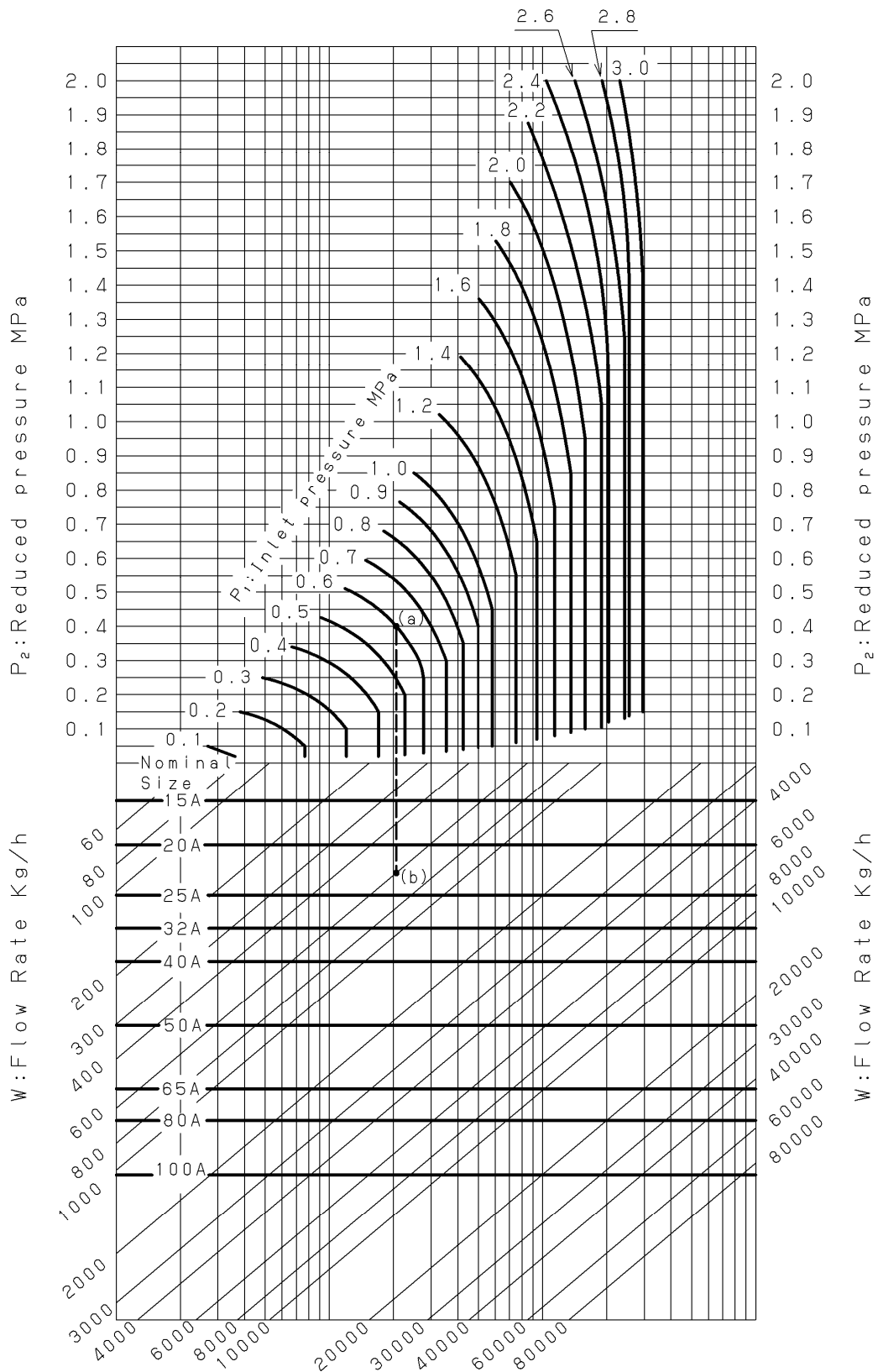

**[Example]**

When selecting the nominal size of a pressure reducing valve with its inlet pressure ( $P_1$ ) is 0.6 MPa, its reduced pressure ( $P_2$ ) 0.4 MPa and its steam flow rate 600 kg/h, first find the intersection point (a) of inlet pressure 0.6 MPa and reduced pressure 0.4 MPa. Trace down vertically from this intersection point (a) to find intersection point (b) with the flow rate of 600 kg/h. Since the intersection point (b) is between nominal sizes 20A and 25A, select the larger one, 25A.



#### 4.4 Nominal size selection calculation formula

An appropriate nominal size can be calculated by obtaining Cv value for the operating conditions in question, as shown below.

- Calculation formula for Cv value

$$P_2 > \frac{P_1}{2}$$

$$C_v = \frac{Wk}{138\sqrt{\Delta P(P_1 + P_2)}}$$

$$P_2 \leq \frac{P_1}{2}$$

$$C_v = \frac{Wk}{120P_1}$$

W: Max. steam flow rate [kg/h]

P<sub>1</sub>: Inlet pressure [MPa·A]

P<sub>2</sub>: Reduced pressure [MPa·A]

ΔP: P<sub>1</sub> - P<sub>2</sub> [MPa]

k: 1 + 0.0013 × {super-heated steam temp. [°C] - saturated steam temp. [°C]}

- Rated Cv value table

Nominal size	15A	20A	25A	32A	40A	50A	65A	80A	100A
Cv value	5.0	7.2	10.9	14.3	18.8	32	60	78	120

[Example]

From the example value in “4.3 Nominal size selection chat”, using a safety factor of 90%\* to the steam flow rate of 600 kg/h, max. steam flow rate(W) is 666.6 [kg/h]. In addition, since P<sub>1</sub>: 0.6 MPa = 0.7 [MPa·A], P<sub>2</sub>: 0.4 MPa = 0.5 [MPa·A], ΔP: 0.2 [MPa] and k: 1, the following formula is established:

$$0.5 > \frac{0.7}{2} \quad C_v = \frac{666.6 \times 1}{138\sqrt{0.2(0.7 + 0.5)}} = 9.9$$

As shown in the above, we obtain the calculated result: Cv = approx. 9.9. Since it is between nominal sizes 20A and 25A in the above “Rated Cv value table”, select 25A which has the Cv value higher than the calculated one.

\* Use a safety factor of 80 to 90% for nominal size selection in view of friction losses in piping.

#### 4.5 Set pressure of safety valve for alarm use at the outlet side of the pressure reducing valve

Set pressure of the pressure reducing valve (MPa)	Set pressure of safety valve (MPa)
Less than 0.1	Set pressure of the pressure reducing valve + more than 0.05
0.1 - 0.4	Set pressure of the pressure reducing valve + more than 0.08
0.4 - 0.6	Set pressure of the pressure reducing valve + more than 0.1
0.6 - 0.8	Set pressure of the pressure reducing valve + more than 0.12
More than 0.8	Set pressure of the pressure reducing valve + 15%

When a safety valve is installed for alarm use at the outlet side of a pressure reducing valve and there are no laws or regulations specified to comply with, select a safety valve whose blowout capacity is around 10% of the maximum flow rate of the pressure reducing valve.

## 5. Installation

### 5.1 Piping example

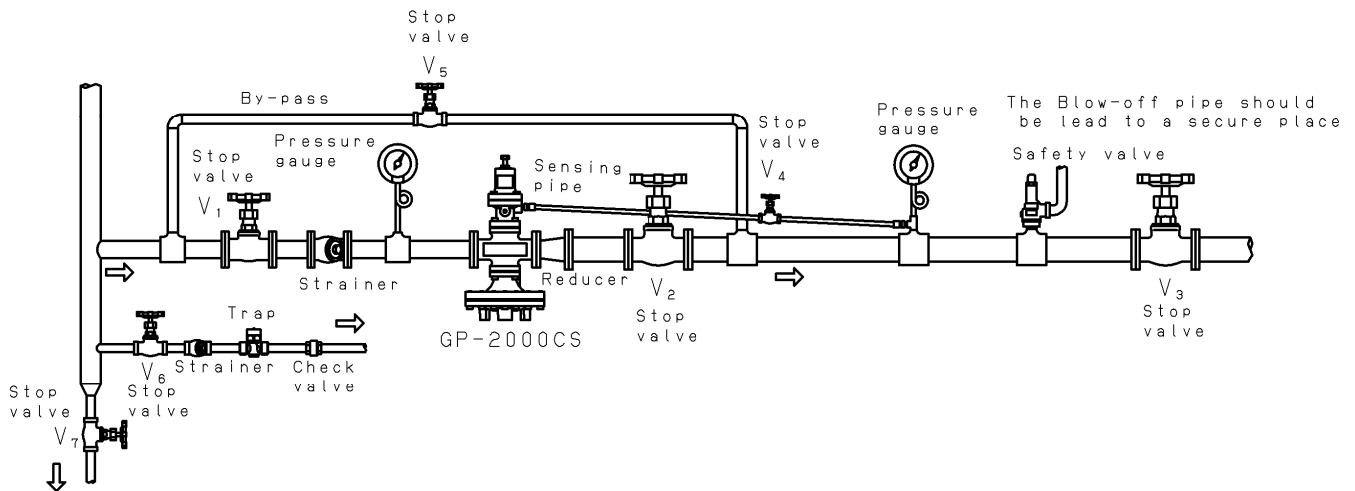

### 5.2 Precaution for installation

#### Warning

1. Since the product is heavy, securely support it with lifting devices or the like while installing. See the product weight specified in Fig. 6 below.  
\* Failure to follow this notice may cause falling accident of the product, resulting in bodily injury.
2. When installing a safety valve for equipment protection at the outlet side of the product, connect a blow-off pipe to the outlet side of the safety valve, and lead it to a place where there is no risk of physical damage even if fluid blows out.  
\* Failure to follow this notice may result in injury and scalds in case of fluid blow out.

#### Caution

1. Before installing the product, remove foreign substances and scale from the piping.
2. Make sure to install a strainer (recommendation: 80 mesh) to the inlet side of the product.
3. Install a safety valve for equipment protection at the outlet side of the product.
4. Make sure to install pressure gauges at the inlet and outlet sides of the product.
5. Make sure to install a trap at the inlet side of the product to prevent hazards caused by condensate.
6. A quick operating valve such as a solenoid valve should be installed at the inlet side of the product. In addition, place it at a distance of at least 3 meters from the product.  
\* Failure to follow this notice may result in malfunction or a drastically shortened service life of the product.
7. For two-stage pressure reduction, take at least 3 meters between each product.  
\* Failure to follow this notice may prevent the product from functioning properly due to malfunction.
8. Confirming the inlet and outlet sides of the product, install vertically to the horizontal piping.
9. Install a bypass line around the product (see 5.1 Piping example).
10. Do not apply excessive load, torque or vibration to the product.
11. If pressure reduction ratio is large, obtain proper piping diameter by installing a reducer in order to prevent excessive flow rate.
12. Since a space around the product is necessary for disassembly and inspection, secure the space specified in Fig. 6 on the page 10 when installing.

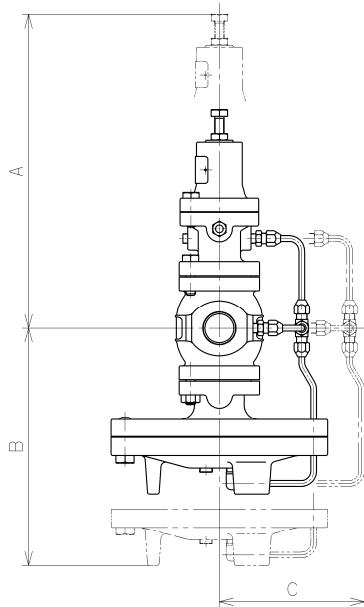

(mm)

Nominal size	A	B	C	Weight (kg)
15A	300	340	180	18.0
The above weight is only for the product with JIS 30 flanged.				
40A	320	380	200	27.0
50A	360	430	220	42.0
65A	380	370	260	75.5
80A	390	390		84.0
100A	410	470	280	133.0

Fig. 6

### 5.3 Warning for installing a sensing pipe



#### Warning

When installing the product, be sure to connect a sensing pipe and a joint to the outlet pipe.  
 \* Failure to follow this notice may result in product malfunction or lead to injury and scalds in case of steam blow out.

### 5.4 Piping example of a sensing pipe

Connect the sensing pipe and the joint from the connection port of the product to the outlet piping as shown in Fig. 7. Make the connection port of the product be above the level of the side opposite to the connection port of the product. In addition, make the length of the sensing pipe less than 5 meters.

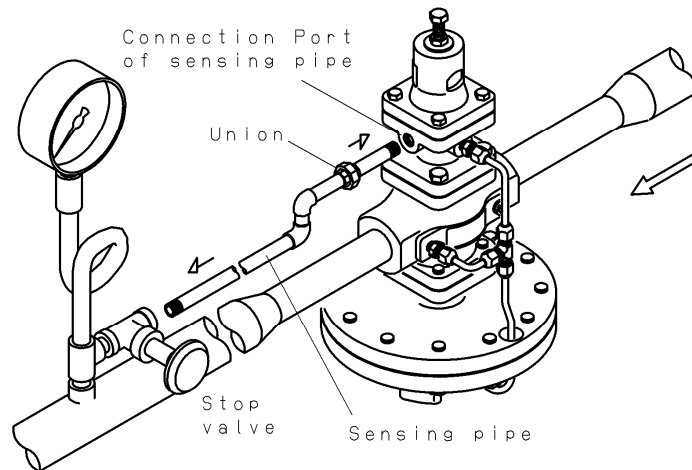

Fig. 7

## 6. Operation procedure

### 6.1 Precaution for operation

#### Warning

1. Do not touch the product with bare hands directly.  
\* Failure to follow this notice may result in scalds.
2. Before applying steam to the product, confirm that there is no risk when steam flows into the piping end and that piping joints are securely connected.  
\* Failure to follow this notice may result in scalds in case of steam blow out.

#### Caution

1. Before leading fluid into the product, close the stop valves at the inlet and outlet of the product and remove foreign substances and scale from the piping completely by using a bypass line.  
\* Failure to follow this notice may prevent the product from functioning properly due to the ingress of foreign substances and scale into the product.
2. Adjust pressure of the bypass stop valve manually to prevent the outlet pressure from going over the set pressure of the safety valve.  
\* If going over, the safety valve blows out.
3. To adjust the set pressure, turn the adjusting screw slowly.  
\* Failure to follow this notice may result in outside leakage or damage of the product due to hunting or water hammer, etc.
4. Before stopping operation of the product for an extended period, completely discharge fluid from the product and close the stop valves at the inlet and outlet sides of the product.  
\* Failure to follow this notice may cause malfunction due to rusting inside the product and the pipes.

### 6.2 Adjusting procedure

Taking a wrong adjusting procedure may cause hunting, scale problems or water hammer, and can heavily damage the main parts of the valve. Be sure to follow the procedure below (see also "5.1 Piping example" on page 8).

1. Confirm that all stop valve ( $V_1$ - $V_7$ ) is closed.
2. Open the stop valve for trap before the product.
3. Open the stop valve ( $V_3$ ) and adjust the opening of the bypass stop valve ( $V_6$ ) so as not to blow the safety valve. Then completely discharge foreign substances by allowing fluid pass through the piping. After discharging, be sure to close the bypass stop valve.
4. Make the adjusting spring [24] be free of any load by loosening the lock nut [28] and turning the adjusting screw [27] counterclockwise.
5. Open the stop valve ( $V_4$ ) of sensing pipe and the stop valve ( $V_2$ ) at the outlet side of the product. Open the stop valve ( $V_3$ ) so that a little fluid can flow through.
6. Slowly open the stop valve ( $V_1$ ) at the inlet side after checking that condensate in the inlet side of the product is discharged from the trap.
7. Slowly turn the adjusting screw till the desired pressure is obtained while watching the pressure gauge at the outlet side. To increase pressure, turn the screw clockwise. To decrease pressure, turn it counterclockwise.
8. Slowly open the stop valve ( $V_3$ ) and tweak the adjusting screw till the desired pressure is obtained in the outlet side.
9. Tighten the lock nuts after this process is completed.

## 7. Troubleshooting

### 7.1 Troubleshooting

Trouble	Cause	Remedy
Reduced pressure of desired level is not obtained.	1. Working pressure is improper.	1. Correct the working pressure.
	2. The screen [15] is clogged.	2. Disassemble and clean.
	3. The main diaphragm [12] is damaged.	3. Disassemble and replace.
	4. Orifice of the tee joint [33] is clogged.	4. Disassemble and clean (see 2 in 7.6 Exploded view).
	5. The pilot valve [17] and/or the pilot valve seat [18] are clogged.	5. Replace the pilot valve assembly [19].
	6. The sensing pipe is clogged.	6. Disassemble and clean.
	7. The nominal size of the product is too small for the specifications of the system.	7. Replace the product of proper nominal size.
	8. The tee is set wrong.	8. Set correctly (see 2 in 7.6 Exploded view).
	9. The strainer on the inlet side of the product is clogged.	9. Disassemble and clean.
	10. Trouble with the pressure gauge	10. Replace.
Abnormal pressure rise at the outlet.	1. Foreign substances stuck between the main valve [6] and the main valve seat [7], or scratches on them.	1. Disassemble the product and remove the foreign substances. Conduct lapping if scratches are found. If the scratches still exist, please contact us.
	2. Foreign substances stuck between the pilot valve [17] and the pilot valve seat [18], or scratches on them.	2. Replace the pilot valve assembly [19].
	3. Orifice of the tee joint [33] is clogged.	3. Disassemble and clean (see 2 in 7.6 Exploded view).
	4. Pressure adjustment is improper.	4. Readjust pressure in accordance with a given procedure.
	5. Trap is not provided on a dead-end line.	5. Install a trap device.
	6. By-pass valve leaks.	6. Repair or replace.
	7. The pilot diaphragm [23] is damaged.	7. Disassemble and replace.
Abnormal sound. Unstable operation.	1. Quantity of flow is less than the minimum controllable flow.	1. The nominal size of the product is too large for the specifications of the system. Replace the product of proper nominal size.
	2. Too much high pressure reduction ratio.	2. Use a two-stage pressure reduction.
	3. Condensate-induced problem.	3. Install a trap device.
	4. A quick operating valve installed near the product.	4. Place the quick operating valve more than 3 meters away from the product.
	5. Outlet pipe diameter is too small.	5. Select a pipe size so that flow velocity can be 30 m/s or less.
Outside leakage.	1. The gasket [16], [45] or [49] is deteriorated or damaged.	1. Replace.
	2. The diaphragm [12] or [23] is damaged.	2. Replace.

Refer to "7.6 Exploded view" for the above parts name.

Most of problems at pressure reducing valve is caused by foreign matter and scales in the piping. Be careful sufficiently.

Phenomenon like valve trouble happens by pressure gauge failure, by-pass valve leakage, forgetting to close by-pass valve or strainer clog. Check the above troubleshooting and take a proper remedy or prevention.

Please contact us if you cannot judge whether damaged parts need to be replaced or not.

### 7.2 Precaution for maintenance and inspection

 <b>Warning</b>
<p>1. Completely discharge the pressure inside of the product, piping and equipment prior to disassembly and inspection. When fluid is hot, cool down the product to the condition that it can be touched with bare hands. Avoid touching the product with bare hands till it is cooled down enough. * Failure to follow this notice may result in scalds, injury or contamination on the surroundings due to the residual pressure.</p>

 <b>Caution</b>
<p>1. Conduct daily and periodic inspection in order to maintain optimum performance of the product. 2. Disassembly and maintenance must be conducted by professional. *In the event of product failure, ask a professional to take measures. 3. When disassembling, put a container under the product to collect condensate flowing out from it. Disassemble the product after condensate is completely discharged from the product. * Failure to follow this notice may result in making the surroundings dirty. 4. Before applying steam to the product, close the stop valves at the inlet and outlet sides of the product and remove foreign substances and scale from the piping completely. * Failure to follow this notice may prevent the product from functioning properly due to the ingress of foreign substances and scale into the product. 5. When adjusting pressure, slowly turn the adjusting screw. * Failure to follow this notice may cause hunting or water hammer, which leads to damage of the product or equipment 6. Before stopping operation of the product for an extended period, completely discharge the fluid from the product and close the stop valves at the inlet and outlet sides of the product. * Failure to follow this notice may cause malfunction due to rusting inside of the product and the pipes. 7. After stopping operation of the product for an extended period, conduct operational check of the product * In the event of product failure, ask a professional to take measures.</p>

### 7.3 Daily and periodic inspections

Conduct daily and periodic inspection in order to maintain optimum performance of the product.

■ Daily inspection (to be conducted once every operational day.)

Items	How to inspect	When abnormality is found
Working conditions	See the pressure gauge and check that working pressure is proper.	See “7.1 Troubleshooting.”
Outside leakage	Inspect the product visually.	See “7.1 Troubleshooting.”

■ Periodic inspection (to be conducted once every year.)

Items	How to inspect	When abnormality is found
Sliding movement of the pilot valve assembly [19], spindle [9] and main valve assembly[20].	Disassemble the product and inspect the movement manually.	If the movement is not smooth, clean or replace the product.
Clogging of the screen [15].	Disassemble the product and inspect visually.	If clogged, clean or replace the product.

## 7.4 Disassembly

Before disassembly, be sure that the stop valves at the inlet and outlet sides of pressure reducing valve are closed. Be careful that all internal pressure and condensate are discharged.

### (1) Disassembly of the pilot valve

1. Loosen the lock nut [28] and turn the adjusting screw [27] to release the adjusting spring [24] (no compression).
2. Remove the bolt [37] and the spring chamber [3]. Then take out the adjusting spring, top spring plate [25], bottom spring plate [26] and pilot diaphragm [23].
3. Remove the entire pilot valve assembly [19] by using ring spanner or socket wrench (nominal size: 22).

### (2) Disassembly of the main valve

1. Remove the pipe A [34] at the joint [30] and tee joint [33].
2. For nominal sizes 15A to 40A, remove the bolt [38] from the pilot body [2] to dismount the pilot body from the body [1]. At the same time, remove the spring plate [14], screen [15], main valve spring [13] and main valve [6].  
For nominal sizes 50A to 100A, remove the bolt [50] from the spacer [51] and upper cover from the main body [1]. At the same time, remove the main valve spring [13] and main valve assembly [20] (for nominal size 50A, main valve spring [13] and main valve [6]).

### (3) Disassembly of the main diaphragm

1. Remove the pipe C [36] at elbow joint [32] and tee [33].
2. Remove the bolt [41] from the bottom diaphragm case [5]. Dismount the bottom diaphragm case, at the same time, remove the main diaphragm [12], retainer [11] and spindle [9] (in addition, remove adapter [53] and retainer [11] for nominal sizes 65A to 100 A).

## 7.5 Precautions for reassembly



### Caution

1. Check that there are no scratches on the main valve, main valve seat, pilot valve and pilot valve seat.  
\* Any scratches at sealing surface lead to increase in secondary pressure. When any scratches are identified on the main valve or main valve seat, make lapping of them. Please contact us if scratches still exist after lapping. If scratches are identified on the pilot valve and pilot valve seat, replace the pilot valve assembly.
2. Confirm that the sliding parts (the pilot valve, spindle, etc) moves smoothly.  
\* If the sliding parts do not move smoothly, it may cause failure problems.
3. Replace gaskets with new ones when reassembling.  
\* If the old gasket is used again, it may cause steam leakage problem.
4. Assemble the parts in reverse order from disassembly. Tighten the bolts uniformly.  
\* Wrong order keeps the product from being assembled correctly. If the hexagon bolts are not tightened uniformly, it may cause steam leakage problem.





---

## Warranty Information

---

1. Limited warranty

This product has been manufactured using highly-advanced techniques and subjected to strict quality control. Please be sure to use the product in accordance with instructions on the manual and the label attached to it.

Yoshitake warrants the product to be free from any defects in material and workmanship under normal usage for a period of one year from the date of receipt by the original user, but no longer than 24 months from the date of shipment from Yoshitake's factory.

2. Parts supply after product discontinuation

This product may be subject to discontinuation or change for improvement without any prior notice. After the discontinuation of the product, Yoshitake supplies the repair parts for 5 years otherwise individually agreed.

3. This warranty does not cover the damage due to any of below:

- (1) Valve seat leakage or malfunction caused by foreign substances inside piping.
- (2) Improper handling or misuse.
- (3) Improper supply conditions such as abnormal water pressure/quality.
- (4) Water scale or freezing.
- (5) Trouble with power/air supply.
- (6) Any alteration made by other than Yoshitake.
- (7) Use under severe conditions deviating from the design specifications.
- (8) Fire, flood, earthquake, thunder and other natural disasters.
- (9) Consumable parts such as O-ring, gasket, diaphragm and etc.

Yoshitake is not liable for any damage or loss caused by malfunction or defect of the product.



INTERNATIONAL DEPT.

7-3, Futanocho, Mizuho, Nagoya, Aichi, 467-0861, Japan

Phone: +81-52-881-7199 Fax: +81-52-881-7201

E-mail: [Intntl@yoshitake.co.jp](mailto:Intntl@yoshitake.co.jp)