

MODEL AL-6

SAFETY RELIEF VALVE

PRODUCT MANUAL

Thank you very much for choosing the Yoshitake's product. To ensure the correct and safe use of the product, please read this manual before use. This manual shall be kept with care for future references. The symbols used in this manual have the following meanings.



	Warning	This symbol indicates a potentially hazardous situation that, if not avoided, could result in death or serious injury.
	Caution	This symbol indicates a hazardous situation that, if not avoided, may result in minor or moderate injury or may result in only property damage.

Table of Contents

1. Specifications.....	1
2. Dimensions and Weights.....	2
3. Structure	3
4. Operation	3
5. Nominal Size Selection Table	4
5.1 For steam (at saturated temperature)	4
6. Installation.....	5-6
7. Maintenance.....	6
7.1 Daily inspection	7
7.2 Monthly inspection	7
7.3 Troubleshooting.....	7-9
Warranty Information	

YOSHITAKE

1. Specifications

Structure	Open lever type
Application	Steam
Working pressure	0.05 to 1.5 MPa* ¹
Max. temperature	220°C
Connection	JIS 10K FF/16K FF flanged* ²

*¹ Maximum Working pressure for 150A is 0.8MPa.

*² JIS 16K FF flanged when working pressure is more than 1.0 MPa.



Warning

1. Do not use the product for equipment or device which cannot allow valve seat leakage.
* The product has allowable valve seat leakage and does not close completely (valve seat leakage cannot be zero).
2. Do not use the product for equipment or device which vibrates excessively.
* Failure to follow this notice may result in malfunction due to vibration.
3. Do not adjust (or change) set pressure.
* Failure to follow this notice may damage equipment.



Caution

- Please confirm that the indications on the product correspond with the specifications of the ordered product model before use.
- * If they are different, do not use the product and contact us.

2. Dimensions and Weights

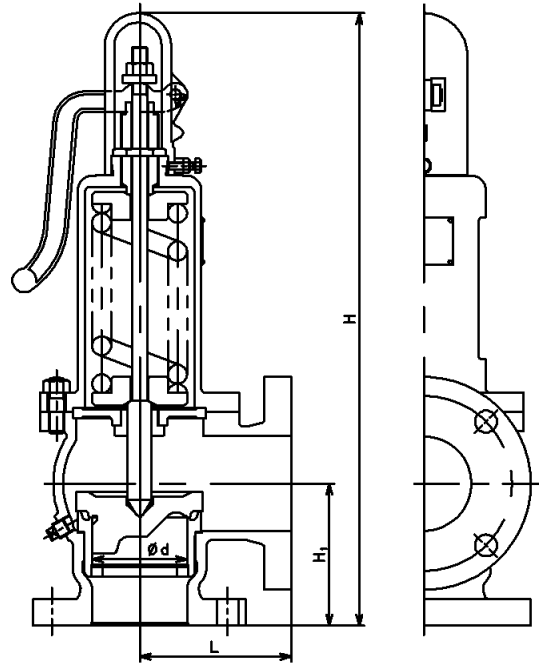
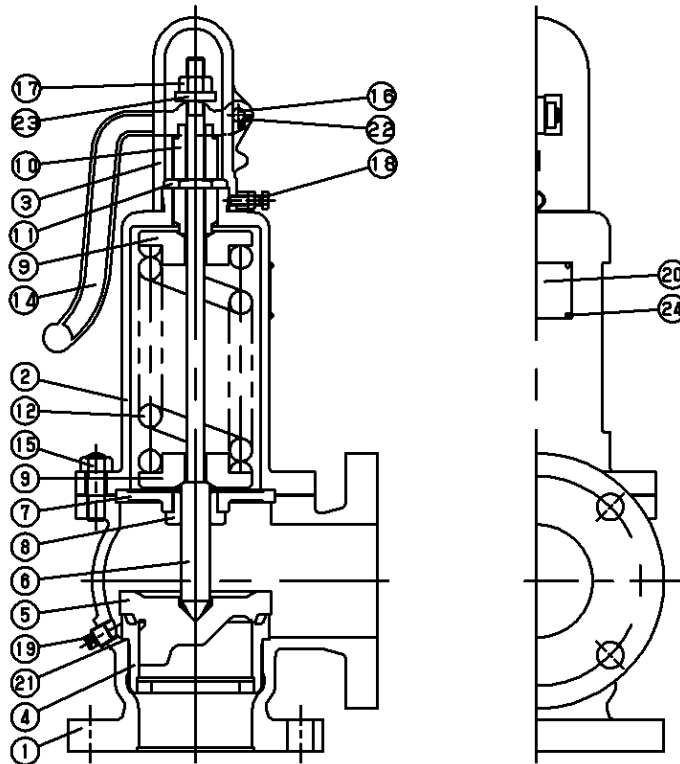

Fig.1 Dimensions

Nominal size	Flow area [mm ²]	Dimensions [mm]				Weight (kg)
		d	L	H ₁	H	
65A	331.9	65	120	120	479	20.2
80A	441.8	75	130	130(132)	493(495)	24.0
100A	785.4	100	160	150(152)	626(628)	44.0
125A	1227.2	125	200	205(207)	835(837)	88.0
150A	1767.2	150	210	215(217)	845(847)	113.0

•The values in parentheses are the dimensions of JIS 16K FF flanged.

3. Structure



No.	Part name
1	Body
2	Spring case
3	Cap
4	Valve seat
5	Valve
6	Spindle
7	Guide plate
8	Spindle guide
9	Spring plate
10	Adjusting screw
11	Lock nut
12	Spring
14	Lever
15	Stud bolt & nut
16	Pin
17	Nut
18	Bolt
19	Plug
20	Name Plate
21	Gasket
22	Split pin
23	Spindle Ring
24	Rivet

Fig.2 Structure

4. Operation

- **Blowout operation**
 As inlet pressure of the product rises and approaches opening pressure, the force of fluid pushing up the valve [5] approaches the force of the spring [12] pressing down the valve [5], and then the product commences to blow. The fluid starts to leak by the simmering and accumulates gradually on the pressure groove. When the fluid pressure reaches the specified opening pressure the valve [5] pops.
- **Closing operation**
 Since the inlet pressure of the safety relief valve decreases when the fluid is released into the atmosphere by the pop action of the valve [5], the force of fluid lift is lowered. At this point, the repelling force of the spring [12] becomes larger than the force of fluid lift and thus the valve closes. In addition, since the safety relief valve blows, the pressure of fluid entering into the back of the valve [5] (back pressure) adds to the closing force.

5. Nominal Size Selection Table

5.1 For steam (at saturated temperature)

<Pressure vessel structure standards>

[kg/h]

Nominal size	Set pressure [MPa]										
	0.05	0.1	0.2	0.3	0.4	0.5	0.6	0.7	0.8	0.9	1.0
65A	263	340	493	663	834	1000	1165	1328	1489	1651	1814
80A	350	452	657	882	1111	1331	1550	1767	1983	2198	2415
100A	622	804	1168	1569	1975	2367	2756	3142	3525	3908	4294
125A	972	1257	1826	2451	3086	3699	4307	4910	5508	6107	6709
150A	1400	1810	2629	3530	4445	5327	6203	7071	7932	—	—

[kg/h]

Nominal size	Set pressure [MPa]				
	1.1	1.2	1.3	1.4	1.5
65A	1976	2138	2299	2461	2621
80A	2631	2846	3060	3276	3489
100A	4677	5059	5440	5825	6203
125A	7309	7906	8500	9102	9692
150A	—	—	—	—	—

<Boiler structure standards>

[kg/h]

Nominal size	Set pressure [MPa]										
	0.05	0.1	0.2	0.3	0.4	0.5	0.6	0.7	0.8	0.9	1.0
65A	255	332	486	640	796	947	1101	1254	1407	1557	1710
80A	339	442	647	851	1059	1261	1466	1670	1873	2073	2276
100A	604	786	1150	1514	1884	2242	2607	2968	3330	3686	4047
125A	944	1228	1797	2366	2944	3504	4074	4638	5204	5760	6324
150A	1359	1769	2588	3407	4239	5046	5866	6680	7494	—	—

[kg/h]

Nominal size	Set pressure [MPa]				
	1.1	1.2	1.3	1.4	1.5
65A	1862	2013	2164	2317	2469
80A	2479	2680	2881	3084	3286
100A	4407	4765	5122	5483	5843
125A	6886	7446	8003	8567	9129
150A	—	—	—	—	—

6. Installation

• Fig. 3 reference.



Warning

1. Do not install any closing device such as a stop valve at inlet and outlet sides of the product.
2. Install an exhaust pipe on outlet side of the product, and lead it to a place where there is no risk of physical damage even if fluid blows out.
* Failure to follow this notice may result in injury and scalds in case of fluid blow out.
3. Do not disassemble the product unnecessarily.
* Failure to follow this notice may prevent the product from functioning properly and lead to danger.
4. Regarding applicable fluid, viscous fluid that may make fixation of the valve and valve seat cannot be used.
* Failure to follow this notice may make valve and valve seat fixed and prevent the product from functioning properly.



Caution

1. Before installing the product, remove foreign substances and scale from the piping.
* Failure to follow this notice may prevent the product from functioning properly due to foreign substance, etc. Note that the customer will be required to pay repair charge for any defect that occurs due to foreign matter.
2. When installing the product, confirm the direction of fluid flow with the inlet and outlet of the product respectively, and install the product correctly.
* Failure to follow this notice may prevent the product from functioning properly.
3. Install the product vertically with the cap [3] facing upward.
* Failure to follow this notice may prevent the product from functioning properly.
4. Securely support and fasten the pipes (Regarding pipe mount and exhaust pipe, see the below).
* If an excessive stress is applied to the product, the product may be deformed and not close.
5. Lead exhaust pipe to outside of buildings if the product is installed on a place where there is a risk that fluid blowout causes alarm activation or contamination of the peripheral equipment.
* Improper placement may cause contamination of the peripheral equipment.
6. Connect the product to the pipes securely.
* Improper connecting may cause fluid leakage from the connection when vibration is applied, or may cause scalds in case that fluid is hot.
7. If there is a risk that condensate or rain water accumulates in exhaust pipe, set a drain pipe in a position where they can be drained.
* Failure to follow this notice may cause rust and result in malfunction.
8. Inner diameters of pipe mount and of exhaust pipe shall be equal to or more than those of each inlet and outlet of the product.
* Failure to follow this notice may result in malfunction or insufficient amount of blowout.

■ Pipe mount of safety relief valve

1. Pipe mount should have sufficient strength and rigidity against shear stress, compressive stress and bending stress which are induced by reaction force in opposite direction of the exhaust through the axis of the exhaust pipe.
2. Pressure loss in pipe mount leads to decrease in the discharge amount and to unstable operation of the product. To prevent them from happening, install the product vertically as close as possible to the can body and the header. In addition, install the product in a position where maintenance and inspection can be done easily.
3. Inner diameter of pipe mount shall be more than that of the product inlet.

■ Exhaust pipe of safety relief valve

1. Install exhaust pipe and drip pan elbow so that the product cannot be subject to the stress caused by thermal expansion of the equipment and by expansion or contraction of the exhaust pipe due to thermal action of blowout.
2. Inner diameter of exhaust pipe shall be more than that of the product outlet to avoid improper back pressure.

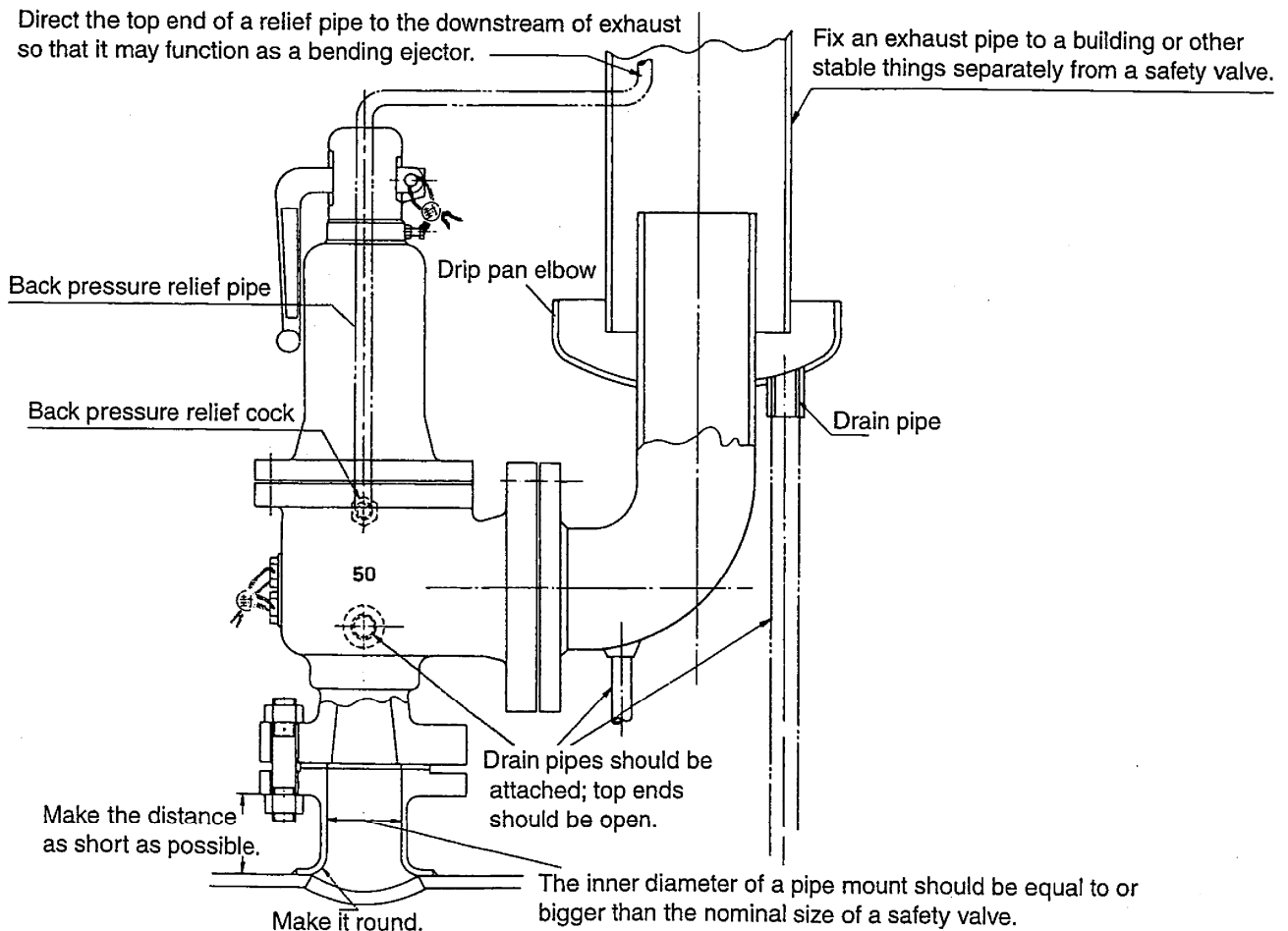

Fig. 3 Piping example

7. Maintenance

Warning

1. Do not touch the product/pipes with bare hands when touching them or operating the lever or operating with lever [14].
* Failure to follow this notice may result in scalds or injury.
2. Do not touch the product unless it is necessary.
* Failure to follow this notice may result in scalds or injury when fluid is high temperature.
3. When checking the operation of the product, wear earplugs and stand clear of exhaust pipe end during inspection. Do not look down or touch the open end of the exhaust pipe.
* Failure to follow this notice may result in injury due to discharge. Be aware that the product makes a loud noise at start-up.
4. Do not disassemble the product.
* Please contact us if any abnormal condition is observed.

Caution

1. Before raising fluid pressure, check that no problems have occurred in the equipment on the piping.
* Failure to follow this notice may damage the equipment.
2. Completely discharge fluid from the product and piping before leaving the product not operated for a long time.
* Failure to follow this notice may cause malfunction due to rust generation in the product or piping.
3. After leaving the product not operated for a long time, make inspection before start-up.

7.1 Daily inspection

Check the following items while the system is in operation.

- Corrosion or crack on the product
- Leakage from the product under normal working pressure (check it visually and aurally).
- Leakage from connection between the product and piping.

* Please contact us if any abnormal condition is observed.

7.2 Monthly inspection (once a month)

1. Check that there is no loose piping at inlet and outlet sides of the product.
2. Check that the operation of the product by making fluid pressure 75% or more of set pressure and lifting the lever.

* Please contact us if any abnormal condition is observed.

7.3 Troubleshooting

Trouble	Cause	Remedy
Fluid leakage at outlet side can be confirmed by sound*.	1. Scale stuck on contact surface between valve [5] and valve seat [4].	1. Follow the procedure described in 7.2.2. and start up the product to remove the scale. If the trouble does not stop, please contact us for repair at our factory.
	2. Damage on contact surface between valve [5] and valve seat [4].	2. The product needs to be disassembled and its parts need to be replaced. Please contact us for repair at our factory.
	3. Excessive vibration is applied to the product and leads to malfunction.	3. The product cannot be used on device or equipment that vibrates excessively.
	4. Pressure difference between the set pressure and the normal working pressure is too small.	4. The pressure difference needs to be enlarged. To readjust the set pressure, the product is readjusted at our factory.
	5. The pressure momentarily exceeds the set pressure because of fluid pulsation.	5. In view of fluid pulsation, the set pressure needs to be raised (readjusted) or the normal working pressure needs to be lowered. To readjust the set pressure, the product is readjusted at our factory.
	6. Fluid flows into the outlet piping.	6. Change the piping layout to keep the fluid from flowing into the outlet piping.

* The product has allowable valve seat leakage and does not close completely (valve seat leakage cannot be zero).

Trouble	Cause	Remedy
Blows at pressure lower than the set pressure.	1. Product specifications are not consistent with usage condition.	1. Check the set pressure indication on the name plate [20]. If the product is not suitable for the usage condition, replace it with a proper one.
	2. Pressure gauge is out of order.	2. Calibrate the pressure gauge or replace it with a new one.
	3. The product does not keep the accuracy of its set pressure.	3. The set pressure needs to be readjusted. Please contact us for repair at our factory.
Does not operate at the set pressure.	1. Product specifications are not consistent with usage condition.	1. Check the set pressure indication on the name plate [20]. If the product is not suitable for the usage condition, replace it with a proper one.
	2. Pressure gauge is out of order.	2. Calibrate the pressure gauge or replace it with a new one.
	3. Sliding portions of the valve [5] and valve seat [4] does not move smoothly	3. The product needs to be disassembled and cleaned. Please contact us.
	4. There is a back pressure at the piping of the product outlet.	4. Remove the back pressure. In addition, change the piping layout not to allow back pressure.
	5. The product does not keep the accuracy of its set pressure.	5. Please contact us for repair at our factory.
Does not stop blowing.	1. Scale stuck on contact surface between valve [5] and valve seat [4].	1. Follow the procedure described in 7.2.2. and start up the product to remove the scale. Please contact us for repair at our factory if the trouble does not stop.
	2. Sliding portions of the valve [5] and valve seat [4] does not move smoothly.	2. The product needs to be disassembled and cleaned. Please contact us for repair at our factory.
	3. The normal working pressure exceeds the closing pressure.	3. Increase the difference between the set pressure and normal working pressure. To readjust the set pressure, the product is readjusted at our factory.
	4. The product is installed at outlet side of the pressure reducing valve which is out of order, and the reduced pressure of the valve is getting higher than expected.	4. The pressure reducing valve needs to be repaired. If it is Yoshitake product, please contact us.

Lever cannot be lifted.	1. Inlet pressure is low.	1. Increase inlet pressure to 75% of set pressure or more.
	2. Sliding portions of the valve [5] and valve seat [4] does not move smoothly.	2. The product needs to be disassembled and cleaned. Please contact us for repair at our factory.
After lever operation, the product does not stop blowing even if letting go of the lever.	1. Scale stuck on contact surface between valve [5] and valve seat [4].	1. Remove the scale by operating the lever again. Please contact us for repair at our factory if the trouble does not stop.
	2. Sliding portions of the valve [5] and valve seat [4] does not move smoothly.	2. The product needs to be disassembled and cleaned. Please contact us for repair at our factory.