

Accessory Parts
附属部品

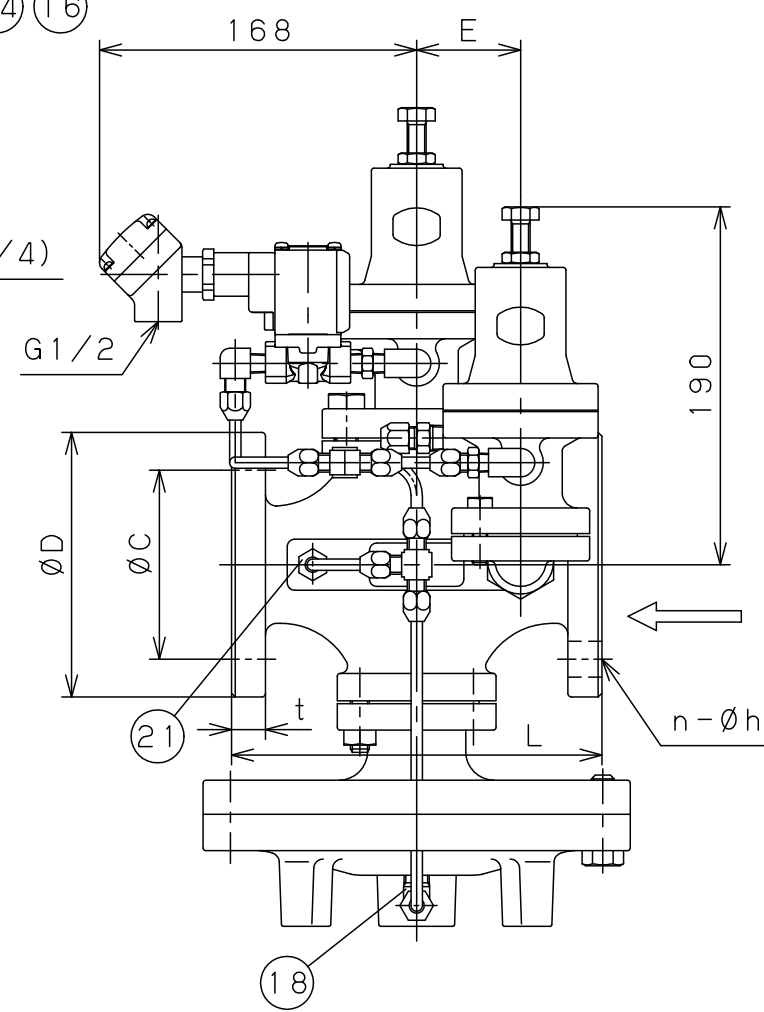
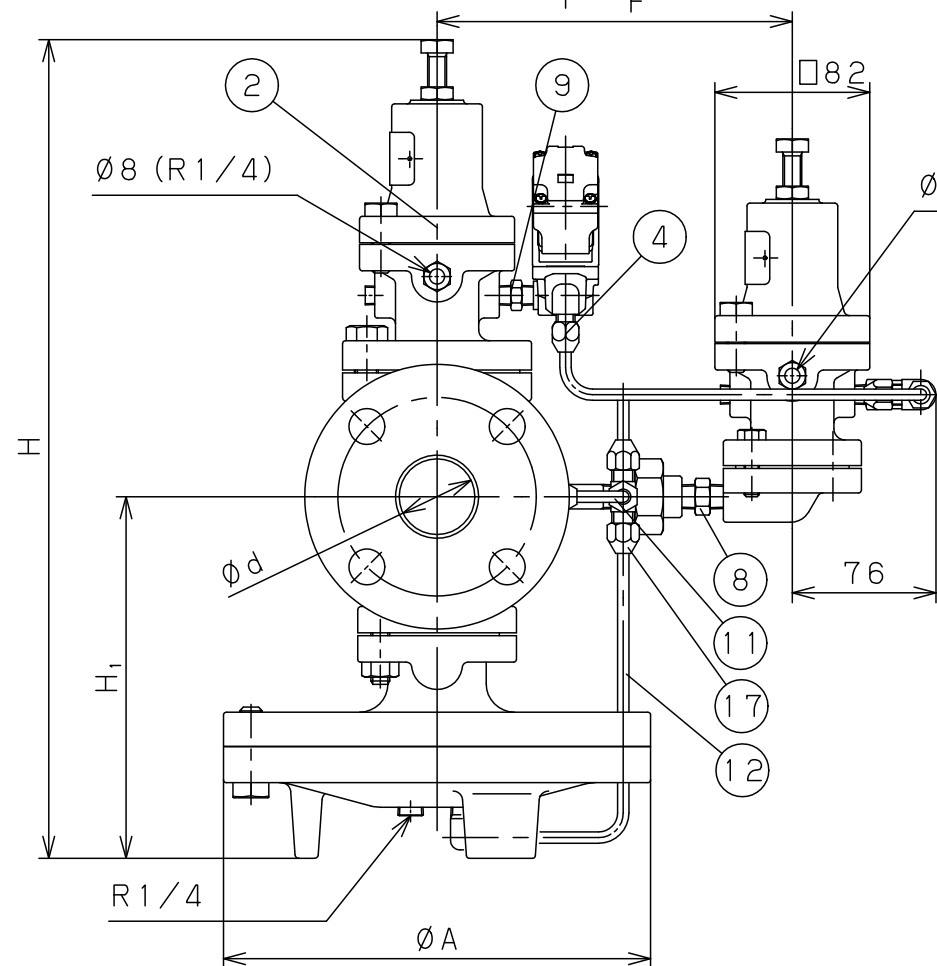

21	Joint	Brass	継手	C3604	1
20	Sensing Pipe	Copper	検出管	C1220	2
19	Sensing Pipe Joint	Brass	検出管継手	C3604	4
18	Elbow	Brass	エルボー	C3771	1
17	Tee	Brass	ティー	C3771	1
16	Joint	Brass	継手	C3604	1
15	Tee	Brass	ティー	C3771	1
14	Pipe F	Copper	導管F	C1220	1
13	Pipe D	Copper	導管D	C1220	1
12	Pipe C	Copper	導管C	C1220	1
11	Pipe B	Copper	導管B	C1220	1
10	Pipe A	Copper	導管A	C1220	1
9	Nipple	Carbon Steel	ニップル 1/8	S25C	3
8	Nipple	Carbon Steel	ニップル 1/4	S25C	1
7	Union	Carbon Steel	ユニオン	S25C	1
6	Long Nipple	Carbon Steel	ロングニップル 1/4	STPG	1
5	Elbow	Malleable Cast Iron	エルボー 1/8	FCMB	2
4	Elbow	Brass	エルボー 1/8	C3771	1
3	Pilot Valve DP-11A (With Terminal Box)	Brass	子弁 DP-11A (端子箱付)	C3771	1
2	Pilot Valve GP-2000BP	Ductile Cast Iron	子弁 GP-2000BP	FCD450	2
1	Main Valve GPM-2000	Ductile Cast Iron	親弁 GPM-2000	FCD450	1
No.	Name of Parts	Material	部品名	材質	Q.TY

Specification	
Fluid	
Inlet Press.	MPa
Reduced Press.	MPa
Temp.	℃
Voltage	V
Operation	
Flow Rate	

Size	L	H ₁	H	A	E	F	Flange JIS 10K FF					Weight (kg)
							d	D	C	t	n-h	
15A	142	170	398	200	45	175	15	95	70	12	4-15	21.2
20A	142	170	398	200	45	175	20	100	75	14	4-15	21.7
25A	152	175	404	226	46	180	25	125	90	14	4-19	26.6
32A	172	192	434	226	55	188	32	135	100	16	4-19	29.5
40A	192	192	434	226	55	188	40	140	105	16	4-19	30.0
50A	218	216	498	276	60	195	50	155	120	16	4-19	41.4
65A	278	251	552	352	75	212	65	175	140	18	4-19	69.7
80A	294	264	575	352	80	223	80	185	150	18	8-19	74.8
100A	330	321	658	401	105	240	100	210	175	18	8-19	112.9

TYPE CP-2003 COMBINATION VALVE
コンビネーションバルブ

Approval	H. Iwamoto
Check	M. Yoshida
Drawing	Y. Aoyama
Drawing No.	Y-786-2205-1A
Date	19 DEC. 2012

